

REV	DESCRIPTION OF REVISION	E.C.N.	CHECKED	APPROVED	DATE
A	ADDED (RoHS EXEMPTED PER ANNEX 7) TO THE SOLDER MATERIAL NOTE.		E.T.W.	E.T.W.	05-16-07

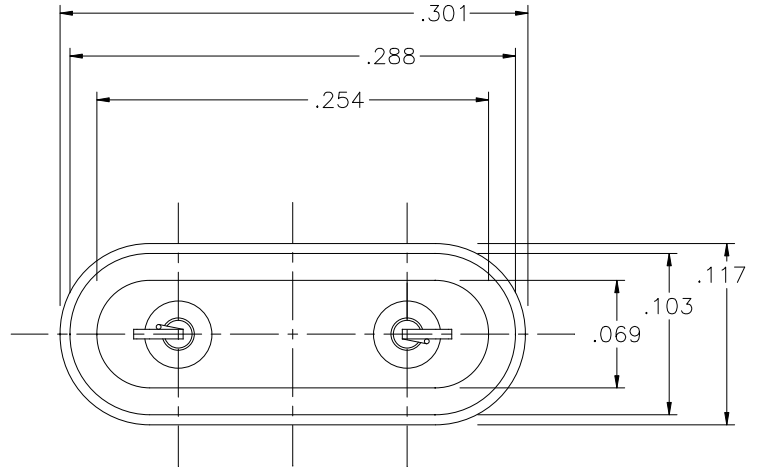

.005 REF.  
.001

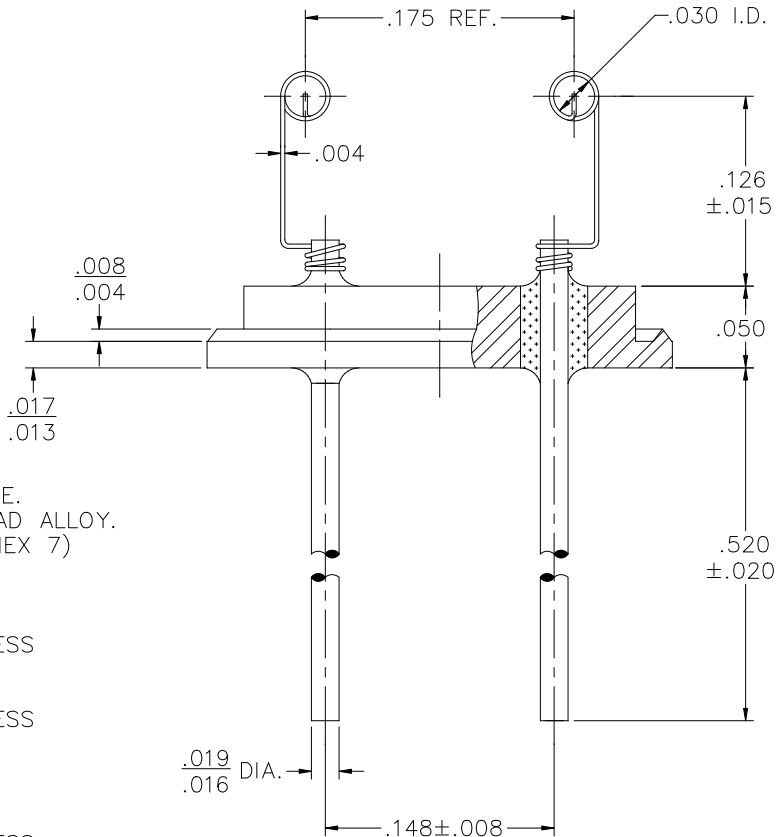
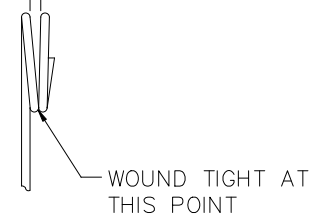

**MATERIAL:**

- EYELET - 1010 C.R.S. OR EQUAL.
- GLASS - 9013 OR EQUAL.
- LEADS - ASTM F-30, 52 ALLOY.
- SPRING - DOUBLE TINNED MUSIC WIRE.
- SOLDER - PER QQ-S-571-D TIN LEAD ALLOY.  
(RoHS EXEMPTED PER ANNEX 7)

**PLATING:**

1. OPTION: RoHS COMPLIANT ELECTROLESS NICKEL PLATE OF 100 MICRONS MINIMUM FINAL PLATE.
2. OPTION: RoHS COMPLIANT ELECTROLESS NICKEL PLATE OF 100 MICRONS MINIMUM FOLLOWED BY A RoHS COMPLIANT LEAD FREE SOLDER COAT, ON LEADS ONLY.
3. OPTION: RoHS COMPLIANT ELECTROLESS NICKEL PLATE OF 100 MICRONS MINIMUM FOLLOWED BY A GOLD FLASH OF .99999 PURE 24 KARAT GOLD UP TO A MAX. OF 8 MICRONS.

DRAWN BY: E.T.W. 08-08-06		MATERIAL: SEE ABOVE		TOLERANCING PER ANSI Y14.5 .X ±.005 .XXX ±.005 .XX ±.005 ANG ±5° UNLESS OTHERWISE SPECIFIED		 6700 W. 47th TERR. MISSION, KS. 66203 TEL: 913-432-2487 FAX: 913-432-0570		
CHECKED BY:		APP. SPECS	SUPERSEDES	NEXT ASSY	SCALE: N.T.S.			FINISH: UNLESS OTHERWISE SPECIFIED
APPROVED BY:		TITLE: HC-45/U TYPE RESISTANCE WELD W/SPRING MOUNT				FILE: VA00030E	PAGE 1 OF 1	A